



**Wilo SP Series
Submersible Sump Pumps ECC**

ECC22-15.33

ECC29-15.50

Installation and operating instructions

1. PREINSTALLATION CHECK

Inspect this pump before it is used. Occasionally, pumps can be damaged during shipping. If the pump or components are deformed, cracked, or there is an leakage, call us Toll Free at: 866-945-6872, or e-mail: info@wilo-usa.com. Monday – Friday between 8 a.m. – 6 p.m., EST. Do not return the pump to the store. ATTEMPTING TO USE A DAMAGED PUMP can result in personal injury or death!

2. DESCRIPTION

This Wilo submersible sump pump is designed for home sump applications. The pump is built with overload thermal protections and auto reset. The pump is equipped with a 10' 3-prong grounding-type power cord and tethered float switch. This pump operates automatically. Ball bearings on motor shafts never need lubrication. Pump only water with this pump. This pump has not been tested or approved for use in swimming pools or in salt-water marine areas. It is also not engineered to be run continuously as a “fountain” or “waterfall” pump.



Do not pump flammable or explosive liquids such as oil, gasoline, kerosene, ethanol, etc. Do not use in the presence of flammable or explosive vapors. Using this pump with or near flammable liquids can cause explosion or fire, resulting in serious personal injury and/or property damage.

3. SPECIFICATIONS

- Power supply required115V, 60 HZ
- Water temperature rangeMax.77°F (25°C)
- Individual branch circuit required 15 Amp minimum
- Discharge Connection1-1/2” FNPT / 1-1/4” FNPT (with adaptor)
- Motor dutyContinuous
- Power cord.....SJTW, 18AWG/3C, 10ft

NOTICE: *This unit is not designed to be used to pump salt water or brine! Use with salt water or brine will void warranty.*

WARNING

4. CONSTRUCTION

- Motor housing Cast Iron
- Motor cap Cast Iron
- VoluteCast Iron
- ImpellerReinforced thermoplastic

5. PERFORMANCE

Model	HP	GPM of Water @ Total Feet of Head					Max. Head
		0	5ft.(1.5m)	10ft.(3m)	15ft.(4.6m)	20ft.(6.1m)	
ECC22-15.33	1/3	53	47	39	27	8	22ft.
ECC29-15.50	1/2	60	53	47	37	25	26ft.

6. GENERAL SAFETY INFORMATION

This pump is made of high-strength, corrosion-resistant materials. It will provide trouble-free service for a long time when properly installed, maintained, and used. However, inadequate electrical power to the pump, dirt, or debris may cause the pump to fail. Please carefully read the manual and follow the instructions regarding common pump problems and remedies.

The following are the general safety requirements. Failure to follow them could cause serious personal injury and/or property damage.

Warning

For your protection and safety, always follow these general rules with pumps:

- ✓ Always disconnect the pump from its power source before installing, inspecting, maintaining, or repairing.
- ✓ Do not stand in water when the pump is connected
- ✓ Do not touch the pump housing while it is operating, as the pump may be HOT and can cause serious skin burns.
- ✓ Do not disassemble the motor housing. The motor has NO repairable internal parts, and disassembling may cause water leakage or dangerous electrical wiring issues.
- ✓ Do not lift pump by power cord or switch cord.

Additional Safety Precautions

1. Know the pump applications, limitations, and potential hazards.
2. Make certain the electrical power source is adequate for the requirements of the pump.
3. ALWAYS disconnect the power to the pump before servicing.
4. Release all pressure within system before servicing any component.
5. Drain all water from system before servicing.
6. Secure discharge line before starting pump. An unsecured discharge line will whip, possibly causing personal injury and/or property damage.
7. Secure the pump on a solid base to keep the pump vertical and above mud and sand during operation to maximize pumping efficiency and prevent clogging and premature pump failure.
8. Check that all pipe connections are tight to minimize leaks.
9. Connect the pump DIRECTLY to a grounded, GFCI outlet.
10. Extension cords may not deliver sufficient voltage to the pump motor. Extension cords present a life threatening safety hazard if the insulation becomes damaged or the connection ends fall into water.
11. Make certain the electrical circuit to the pump is protected by a 15 Amp or larger fuse or circuit breaker.
12. Periodically inspect the pump and system components to be sure the pump inlets are free of mud, sand, and debris. DISCONNECT THE PUMP FROM THE POWER SUPPLY BEFORE INSPECTING.
13. Do not handle pump or pump motor with wet hands or when standing on wet or damp surface, or in water. Wear safety glasses at all times when working with pumps.
14. Follow all electrical and safety codes, particularly the National Electrical Code (NEC) and in the workplace, the Occupational Safety and Health Act (OSHA).
15. This unit is designed only for use on 115 volts (single phase), 60 Hz, and is equipped with an approved 3-conductor cord and 3-prong grounded plug. DO NOT REMOVE THE GROUND PIN UNDER ANY CIRCUMSTANCES. The 3-prong plug must be directly inserted into a properly installed and grounded 3-prong, grounding-type receptacle. **Do not use this pump with a 2-prong wall outlet.** Replace the 2-prong outlet with a properly grounded 3-prong receptacle (**a GFCI outlet**) installed in accordance with the National Electrical Code and local codes and ordinances. All wiring should be performed by a qualified electrician.
16. Protect the electrical cord from sharp objects, hot surfaces, oil, and chemicals. Avoid kinking the cord. **Do not use damaged or worn cords.**

7. INSTALLATION

Warning

Always use the handle to lift the pump. Never use the power cord to lift the pump. To avoid skin burns, unplug the pump and allow time for it to cool after periods of extended use.

1. Install the pump in sump pit with minimum diameter of 18" (46cm). Sump pit depth should be 30" (76cm). Construct sump pit of tile, concrete, steel, or plastic. Check local codes for approved materials and for proper installation.
2. Clean sump pit of small stones, gravel, or mud. Secure the pump on a level, solid base. Do not suspend the pump by the discharge pipe, hose, or power cord.
3. Install discharge plumbing and a check valve in the vertical pipe to prevent flow backwards through the pump when it shuts off. Use rigid plastic pipe and wrap threads with Teflon tape, **NOT pipe joint compound**. Screw pipe into pump hand tight plus 1-1/2 turns.
4. Drill a 1/8" hole in discharge pipe about 1"-2" (2.5 - 5.1cm) above pump discharge connection (but below check valve) to prevent air-locking the pump.
5. To reduce motor noise and vibrations, a short length of rubber hose can be connected into discharge line near pump using suitable clamps.
6. After the installation of the necessary plumbing, check valve, and rubber hose, follow the glue manufacturer's instructions for safety precautions and curing time. The pump is ready for operation.
7. Pump is designed for 115 V., 60Hz, operation and requires a minimum 15 amp individual branch circuit.
8. Check the pump by filling the sump pit with water and observe the pump's operation through one complete cycle. Make sure the pump cannot move in the sump pit and the float switch moves freely up and down.

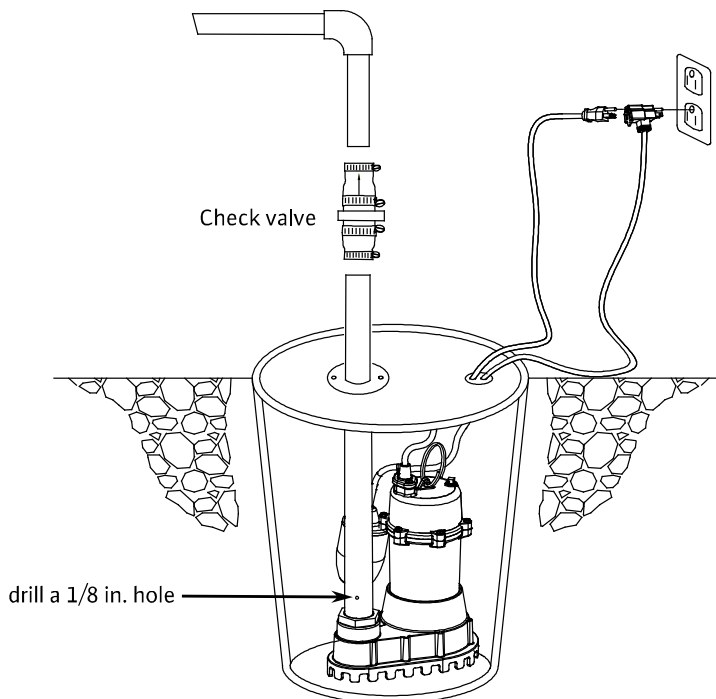

Picture 1

8. OPERATION

Warning

Do not handle this pump or plug in or unplug this pump with wet hands or while standing in water, unless you are certain all power has been turned off to the pump. Remember, the pump should be connected only to a properly grounded, GFCI outlet.

Running the pump without sufficient water will damage the pump and void the pump's warranty.

1. Make certain the pump is submerged in water. Running the pump dry can damage the shaft seal.
2. Plug the pump power cord plug into the piggyback switch plug outlet, and then plug the switch plug into a 115V GFCI power outlet. When the float switch moves up over the pump top the pump will start operating. The water will be pumped out. When the water lowers to a certain level, the float switch will turn off the pump. This pump also can operate manually if the switch fails. Directly plug the power cord plug into a 115V GFCI power outlet. The pump will pump water out.◦
3. The motor is equipped with an automatically resetting thermal overload protector. If the motor gets too hot, the overload protector will shut off the pump before it is damaged. When the motor has cooled sufficiently, the overload protector will reset, and the motor will restart.

NOTICE: *If the overload protector stops the pump repeatedly, disconnect the power from the pump and allow the pump cool to the safety temperature then check to find the problem. Low voltage, a long extension cord, clogged impeller, screen blocked by debris, or water that is too hot can cause motor overheating.*

9. Maintenance

- Periodically unplug the pump, making certain your hands are dry, and you are not standing in water. When the power is disconnected, inspect the pump inlets and remove all debris, then plug pump back into the grounded (GFCI) outlet.
- To clear a pump clogged with debris, first, **UNPLUG PUMP** from electrical power. Then referring to **Picture 2** below, unscrew the stainless screws #5, then the diffuser #4, and the seal gasket #3. Use a flathead screwdriver to hold the shaft #1 then turn the impeller #2 counter-clockwise to release the impeller. Remove debris from around the shaft and on and under the impeller. Then reassemble the impeller, gasket, volute, See **Picture 2**.

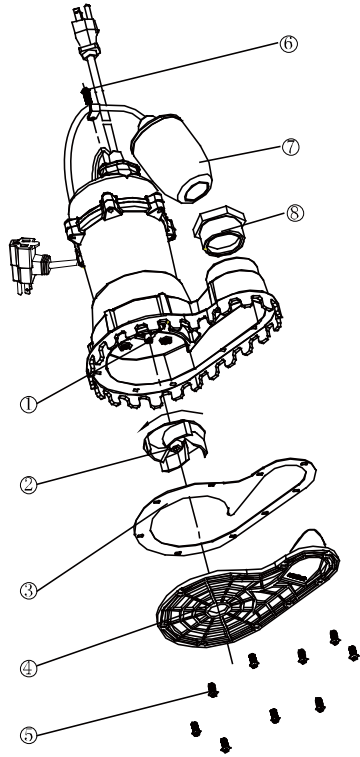

No.	Description	Qty.
1	Shaft	1
2	Impeller	1
3	Gasket	1
4	Diffuser	1
5	Screw M5X12	10
6	Screw M5X16	2
7	Tether float switch	1
8	Hose adaptor	1

10. TROUBLESHOOTING

Do not disassemble the motor housing. This pump has NO repairable internal parts, and disassembly may cause an oil leak or dangerous electrical wiring conditions.

Table2 Troubleshooting Common Pump Problems

Problem	Possible Cause	Corrective Action
Pump does not start or run	<ol style="list-style-type: none"> Blown fuse Tripped breaker Plug disconnected Corroded plug Thermal overload Float switch failed Motor failed 	<ol style="list-style-type: none"> Replace fuse Reset breaker Secure plug Clean plug prongs Unplug for 30 minutes, then plug in Directly plug the power cord into the power source outlet. If the pump works, the switch must be faulty. Replace switch. Directly plug the power cord (skip switch) into the power source outlet. If the pump doesn't work or motor is humming, the motor must be faulty. Replace pump.
Pump operates but pumps little or no water	<ol style="list-style-type: none"> Screen blocked Debris caught in the impeller or discharge Impeller broken 	<ol style="list-style-type: none"> Clean screen Remove debris Replace impeller
Pump starts and stops too often	<ol style="list-style-type: none"> Backflow of water from piping or check valve leaking Tangled switch Float Switch failed 	<ol style="list-style-type: none"> Install a check valve or replace the check valve Reposition the pump and make sure the switch moves freely Replace switch
Pump will not shut off	<ol style="list-style-type: none"> Tangled switch Faulty float switch Float obstructed 	<ol style="list-style-type: none"> Reposition the pump and make sure the switch moves freely Replace switch Remove obstruction

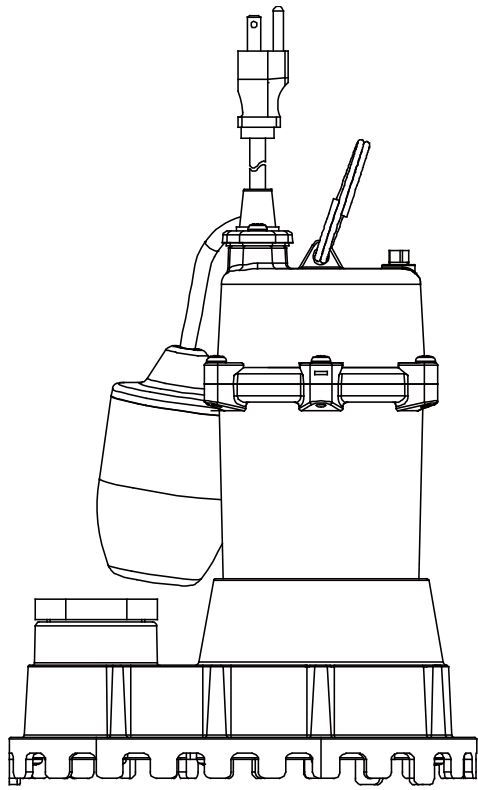

WILO USA LLC

Tel: 262-204-6600
Fax: 229-558-9015
Email: info.us@wilo.com
Web: www.wilo-usa.com

Wilo Canada Inc.

Tel: 403-276-9456
Fax: 403-277-9456
Email: info@wilo-canada.com
Web: www.wilo-canada.com

Wilo Mexico

Tel: + 52 55 5586 3209
Fax: + 52 55 5586 3209
Email: info@wilo.com.mx
Web: www.wilo-mexico.com

